



CASE  
STUDY

# Triflex

Delivering solutions together.

ROOF REFURBISHMENT  
POTTERS QUAY, BELFAST

## POTTERS QUAY BUSINESS CENTRE

### Authorised Contractor

GBS Roofing Ltd

### Area

700m<sup>2</sup>

### Systems

Triflex ProTect®

Triflex ProDetail®

### Scope of work

Warm roof refurbishment

📞 01785 819119

🌐 [www.triflex.co.uk](http://www.triflex.co.uk)

✉ [info@triflex.co.uk](mailto:info@triflex.co.uk)

📄 Triflex (UK) Ltd

🐦 @TriflexUK

Triflex (UK) Ltd. | Whitebridge Way | Stone | Staffordshire | ST15 8JS



# The challenge

The roof on Potters Quay Business Centre in Belfast, with its original single-ply membrane covering, was beginning to show signs of nearing the end of its serviceable life. The client required a cost-effective waterproofing solution that would provide protection for years to come.

Initially it had been agreed that the solution would be to remove the existing single-ply membrane roof covering and replace like-for-like. However, a more timely and cost effective option was proposed using a tried and tested Triflex overlay solution.

With minimal repairs, the current single ply membrane substrate could be overlaid with the Triflex ProTect waterproofing system, not only leading to less disruption to the office below, but also considerably reducing installation time and the risk of any water ingress.

Current building regulations for Northern Ireland covered within Technical Handbook F2 state that should in excess of 50% of the roof area be repaired or replaced, then the roof should be thermally upgraded.

A comprehensive survey of the roof was carried out by Triflex to assess its condition and to help provide a detailed Triflex specification proposal.

Following core testing conducted by Triflex field technicians on site, it was identified that the existing build up was a bonded single ply system. The tests revealed that there were areas of delamination of the membrane and water damage to the insulation, affecting the performance and bond to the deck.





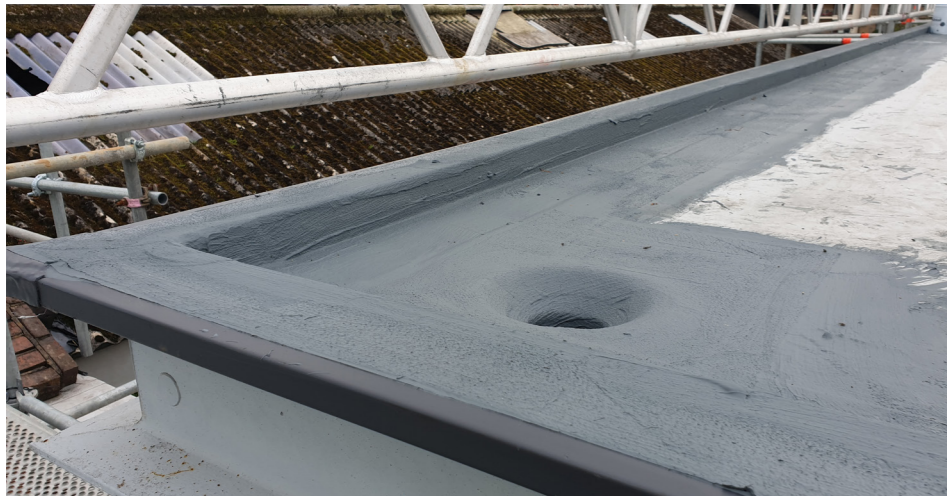

# The solution

The comprehensive Triflex survey identified a need to remove approximately 20% of the roof insulation. As a result, Triflex were able to suggest a partial replacement of the insulation. This was to the same depth and U-value of the existing roof build up coupled with an overlay of a Triflex system to the 700m<sup>2</sup> roof area.

With the client's budget considerations in mind for the selection of a suitable waterproofing solution, this proposal identified a key cost saving. By leaving the insulation in-situ, and most of the roof covering intact, the cost of overlaying with a Triflex system was far less expensive than removing and replacing like-for-like. It also reduced the risk of opening and exposing the roof and the subsequent office space below to rainfall during the works.

From a design perspective, the roof had a large, cantilevered perimeter with a very shallow profile. By overlaying, we were able to maintain this thin line around the perimeter. Had a full thermal upgrade been required, the thickness of the profile would have needed to have been increased by around 160 mm.

Due to its exceptional and tested compatibility with single-ply, Triflex ProTect was specified, with Triflex ProDetail to waterproof detailed areas. With the system's ultra-fast curing abilities, it is rainproof in as little as 30 minutes and can be installed in temperatures down to 0°C, allowing works to be completed even in cold winter months.

The high quality installation by GBS Roofing Ltd of the Triflex system has ensured that the Potters Quay Business Centre in Belfast has a cost effective waterproof solution and has also reduced wastage by extending the life of the existing roof. And with a trusted, proven, and warrantied system, they can rest assured will do so for many years to come.



System benefits

## Triflex ProTect®

- Totally cold applied, with no risk from hot works
- Compatible with virtually all roof substrates
- Suitable for all roof build-ups and applications
- Exceptionally rapid curing / rainproof times, even at low temperatures
- Fully reinforced waterproofing technology
- Suitable for zero pitch, completely flat and pitched roofs
- Simple, single process waterproofing application
- Hydrolysis (standing and ponding water) resistant

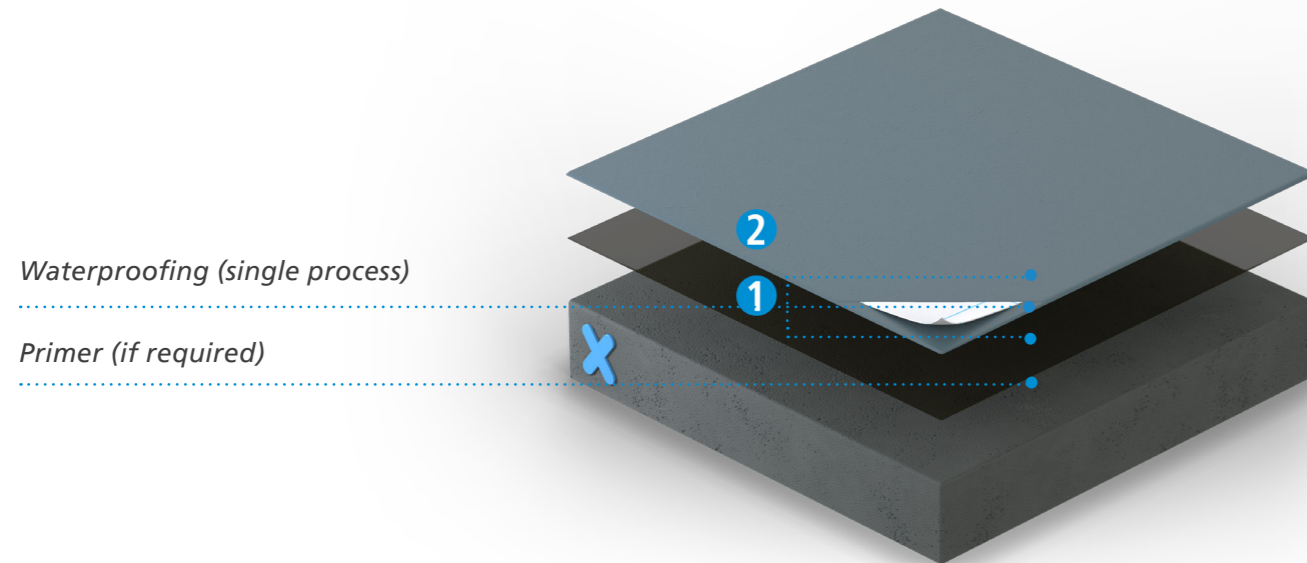

System benefits

## Triflex ProDetail®

- Waterproof down to the smallest detail
- Compatible with virtually all substrates including asphalt
- Cold applied, fast curing with rapid installation
- Simple, single process waterproofing application
- Rapid curing system - even at low temperatures
- Fully reinforced technology
- Certified to the highest standards

Waterproofing (single process)

Primer (if required)

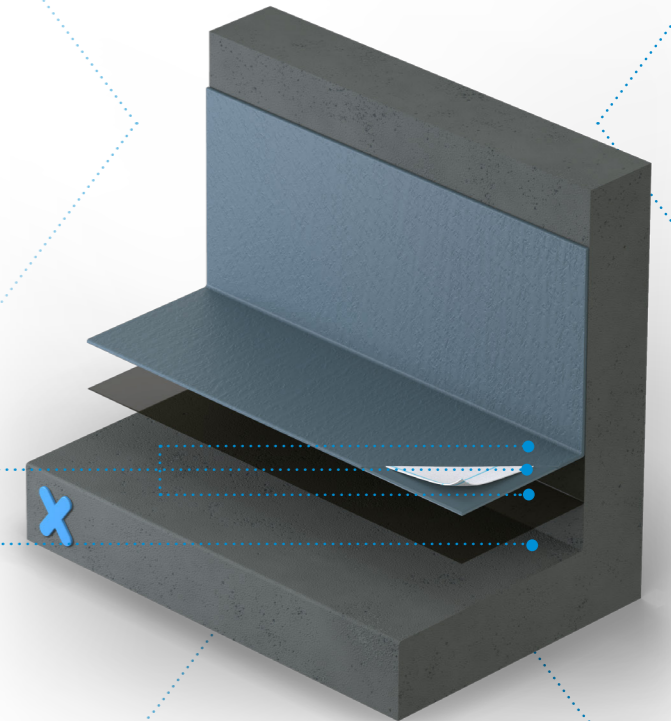



Delivering solutions together.

Triflex is the leading European specialist in cold liquid applied resins. Our high-quality systems provide reliable and lasting waterproofing, surfacing, protection and markings for roofs, walkways, balconies, terraces and car parks. We are a family owned and operated company that provides individual solutions worldwide. From our production facilities based in Minden, Germany, we have been researching and developing solutions designed to protect and repair the built environment for more than 40 years.

From our UK headquarters based in Stone, Staffordshire we pride ourselves on providing our clients with tailored solutions and exceptional levels of service and support throughout all stages of their project. From conducting in-depth site surveys, to our comprehensive testing and off-site and on-site support, we ensure that your project is completed on time and to the highest standards. All Triflex solutions are certified to the highest standards and are backed up by long term meaningful warranties ensuring peace of mind.

 01785 819119

 [www.triflex.co.uk](http://www.triflex.co.uk)

 [info@triflex.co.uk](mailto:info@triflex.co.uk)

 Triflex (UK) Ltd

 @TriflexUK

Triflex (UK) Ltd. | Whitebridge Way | Stone | Staffordshire | ST15 8JS

